



# Model 53BTX—Ball Type Duplex Basket Strainer

Sizes 3/4" to 4" • Iron, Bronze, Carbon Steel or Stainless Steel • Threaded or Flanged

Easy Basket  
Changeout



**Patented diverter cartridge assures leak-tight isolation of basket chamber during cleaning.**

No more rushing to finish the job before the out of service chamber overflows. And... with no overflow, there's no clean-up.

#### Features

- Dynamic ball sealing system for long life...patent pending
- Easy-to-operate lever handle... no gear box required
- Unique seat and seal design requires no adjustments
- Reinforced polymer seats for longer service life
- Foot pads for rock solid installation
- Double-stem o-rings for positive sealing
- Easy-to-access body vent valve
- Both side and bottom drain plugs on each basket well
- Piston seal strainer basket cover
- Easy access for diverter cartridge removal



#### No-Hassle Strainer Basket Servicing

Hayward duplex strainers remove dirt and debris from pipelines and protect sensitive system components. The Model 53BTX, features a design that makes strainer basket servicing a no-hassle operation. No more "race against the clock" during basket servicing to get the job done before the basket chamber overflows with fluid. The Model 53BTX keeps the chamber dry during service. This gives you time to clean or replace the strainer basket without ever having to worry about leakage and overflow. And...without overflow, there's no need to clean up after servicing the strainer basket. The Model 53BTX is simply a better way to work.

#### A Better Duplex Strainer Design

A unique flow diverter valve cartridge in the Model 53 BTX isolates the two strainer basket chambers and prevents fluid bypass. An easy-to-turn handle operates the cartridge and diverts the system flow from one

chamber to the other—the flow in the pipeline is never shut off.

When a strainer basket needs to be cleaned, the lever handle is turned to take it out of service and to divert the flow through the other chamber. The position of the handle clearly indicates at all times which chamber is in service.

No special tools are needed to access the strainer basket for cleaning. The chamber is first drained and then the cover is lifted and swung clear of the chamber opening. The dynamic diverter cartridge seals prevent fluid bypass into the out-of-service chamber—making for easy, hassle-free strainer basket servicing.

#### Hayward's Better Flow Diverter Cartridge

The heart of the Model 53BTX is the unique flow diverter cartridge that features a patent pending, highly dynamic sealing system on the diverter balls that ensures exceptionally long seat life and positive

### Selection Table

Size	Body & Cartridge Material	Connection	Seat/Seal	Diverter Balls	Rating
3/4", 1", 1-1/4", 1-1/2", 2", 2-1/2"	Iron	Threaded	Buna N* / PPL	Stainless Steel**	125# ANSI 200 PSIG @ 150F
1", 1-1/2", 2", 2-1/2", 3", 4"		Flanged			
3/4", 1", 1-1/4", 1-1/2", 2", 2-1/2"	Bronze	Threaded			150# ANSI 200 PSIG @ 150F
1", 1-1/2", 2", 2-1/2", 3", 4"	Carbon Steel Stainless Steel	Flanged			

\* Viton® optional for iron, bronze and carbon steel, standard for stainless steel  
\*\* Nickel-plated SS balls optional

DIN flanges and BSP threads available



1" stainless steel Model 53BTX with flanged connection

# Model 53BTX Ball-Type Duplex Basket Strainer



sealing. The Hayward design works so well that there is no need for manual internal or external ball support adjustments—and the low operating torque means the strainer can be operated with an easy-turn lever handle. A gear box is not needed.

A double sealing system on both the upper and lower stems guards against any possible leakage. Special reinforced polymer seats are used for extended service life.

Should cartridge service become necessary, it's easy to accomplish. Just remove four bolts and the cartridge comes right out through the top of the strainer. There's no need to take the strainer completely apart or to remove it from the line.

## Better for All Applications

The compact, low profile Model 53BTX fits into spaces ordinary strainers might not, yet it still uses full-size strainer baskets with a low pressure drop performance.

And, there's a strainer basket for every application. The standard basket is made of Type 316 stainless steel; however, if required, Monel, Brass or Hastelloy C materials are available. Baskets with openings from 3/4" down to 45 microns are offered: choose the best size for your application—with no compromises.

For easy basket servicing there are two drain plugs, not just one, on each strainer basket chamber. Additionally, there is an easy-to-access vent valve on top of the strainer body.

Finally, standard foot mounting pads insure a rock solid installation no matter where the strainer is installed.

Available options for the Model 53BTX include differential pressure gauges, with or without switches, and magnetic separators installed in the strainer basket for removing fine ferrous particulate matter from the process media.



*Should the diverter valve require service, it slides right out the top of the strainer body. A minimum of parts, easily replaced, makes service a snap. Exploded view shows simplicity of design.*

## Technical Details

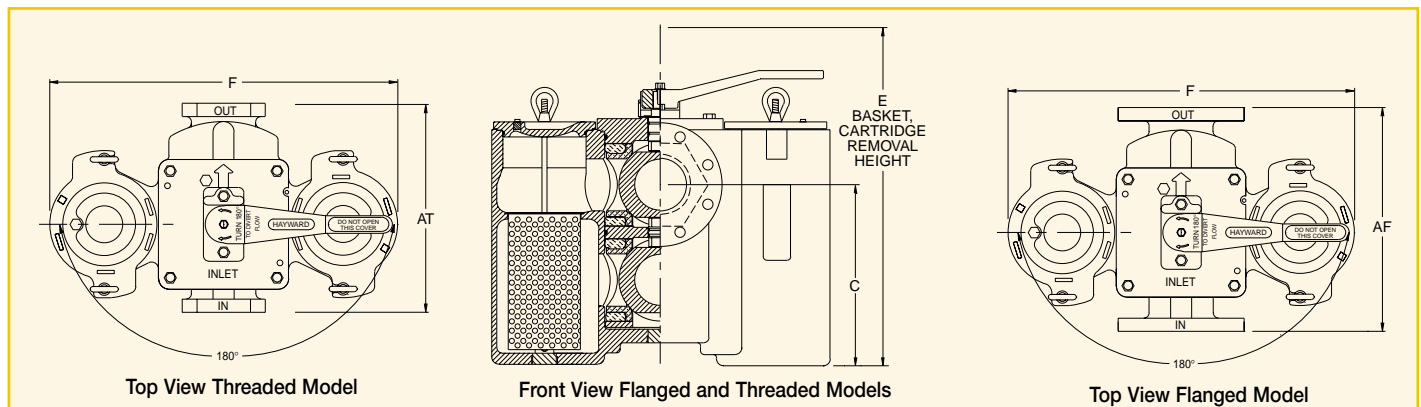

Dimensions and weights are for reference only. Contact Hayward for certified drawings.

## Dimensions (in / mm)

Pipe Size	AF	AT	C	E	F	Weight – Iron		Weight – Bronze		Weight – Carbon & SS	
						Flanged lb / kg	Threaded lb / kg	Flanged lb / kg	Threaded lb / kg	Flanged lb / kg	Threaded lb / kg
3/4	—	5.50 / 140	5.00 / 127	13.38 / 340	10.50 / 268	—	37 / 17	—	46 / 21	—	41 / 19
1	6.88 / 175	5.50 / 140	5.00 / 127	13.38 / 340	10.50 / 268	42 / 19	37 / 17	52 / 24	46 / 21	47 / 21	41 / 19
1-1/4	6.88 / 175	7.50 / 190	6.81 / 173	17.00 / 432	13.25 / 330	—	80 / 36	—	100 / 45	—	89 / 40
1-1/2	9.38 / 238	7.50 / 190	6.81 / 173	17.00 / 432	13.25 / 330	90 / 41	80 / 36	113 / 51	100 / 45	100 / 45	89 / 40
2	10.63 / 270	10.00 / 254	8.38 / 213	21.75 / 552	17.38 / 441	167 / 76	157 / 71	209 / 95	197 / 90	185 / 84	174 / 79
2-1/2	10.75 / 273	10.00 / 254	8.38 / 213	21.75 / 552	17.37 / 441	183 / 83	157 / 71	229 / 104	197 / 90	203 / 92	174 / 79
3	13.50 / 343	—	8.88 / 226	26.50 / 673	22.75 / 578	285 / 129	—	357 / 162	—	432 / 196	—
4	16.00 / 406	—	13.25 / 337	33.00 / 838	24.75 / 629	389 / 177	—	487 / 221	—	432 / 196	—

PROSEP FILTER SYSTEMS LTD  
Unit G19  
River Bank Way  
Lowfields Business Park  
Elland  
West Yorkshire  
HX5 9DN

**Tel: 01422 377367**

**Fax: 01422 377369**

Email: [enquiries@prosep.co.uk](mailto:enquiries@prosep.co.uk)

[www.prosep.co.uk](http://www.prosep.co.uk)

**Map and Directions to Prosep Filters Limited**

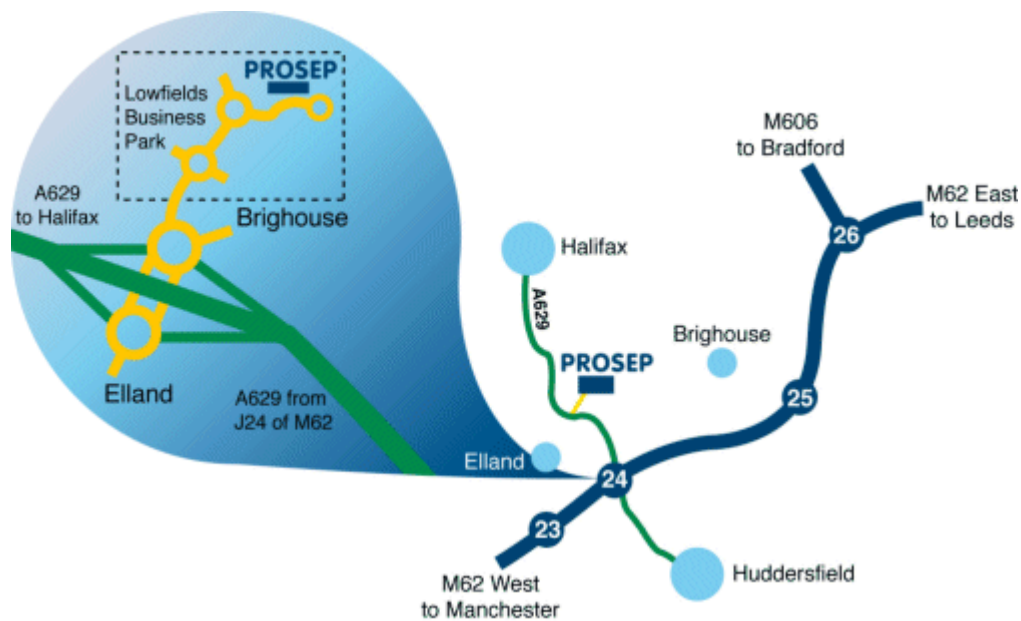

Leave M62 at Junction 24.

At roundabout adjacent to Cedar Court Hotel take 2nd exit onto dual carriageway (A629), signposted Halifax.

Take 1st exit slip road.

At roundabout at end of sliproad, take 3rd exit off.

This is the entrance to Lowfields Business Park.

Proceed straight over 1st roundabout.

At next roundabout take 2nd exit onto River Bank Way - Prosep Filters can be found on the left after the S-bend.

[Link to Google Maps](#)