



Model 72 Simplex Basket Strainer

Sizes 3/8" to 8" • Iron, Bronze, Carbon Steel or Stainless Steel • Threaded or Flanged

The Industry Standard Simplex Strainer



Features

- Quick open cover – no tools needed
- Heavy wall construction
- Large capacity baskets
- Machined Basket seat
- Threaded drain
- Perforated Stainless Basket

Options

- Basket perforations from 1/32" to 1/2"
- Basket mesh from 20 to 400
- Monel baskets
- Viton, PTFE-encapsulated, or EPDM seals
- Vent valves
- 1/4" NPT taps
- Magnetic basket inserts
- Pressure differential gauge and switch



Hayward's Model 72 Simplex Strainer has been the industry standard simplex basket strainer for over 75 years. It's perfect for industrial and commercial applications where the line can be temporarily shut down for strainer basket cleaning or changeout.

A few of the reasons for its popularity are, first, the unusually large basket capacity. The free straining area is at least 6 times the cross sectional pipe area (even more in many sizes). Next, no tools are needed to open the cover. The quick opening, swinging yoke can be disassembled and the basket removed in seconds. On sizes 4" and larger, a special cover clamp is provided to distribute the seating pressure and to insure positive seating of the cover.

Another feature is a threaded drain on every size strainer (fitted with a plug). This can be used as a backwash connection, if desired. Sizes 2" and larger are provided with legs for bolting to the floor for rock solid installation.

Wall thicknesses are exceptionally heavy. We have not stinted on weight to save material costs. The basket seats are precision machined to give a tight seal and prevent any material from by-passing the basket. The Hayward Model 72 Simplex Basket Strainer is a top quality, heavy duty unit designed to stand up to the most demanding of applications. There is simply no better simplex basket strainer made.

Model 72 Simplex

Size	Material	End Connection *	Seals	Pressure Rating
3/8" to 3"	Iron and Bronze	Threaded	Buna N	200 psi @ 100F
1" to 3"	Carbon Steel		Viton®	
	Stainless Steel			
1" to 8"	Iron	Flanged 125#	Buna N	
	Bronze	Flanged 150#		
	Carbon Steel			
	Stainless Steel		Viton®	

* DIN flanges and BSP threads available

Mod. 72C_v Factors*

Size	Value	Size	Value
3/8"	15.0	2"	73
1/2"	15.0	2-1/2"	125
3/4"	15.0	3"	180
1"	22.5	4"	350
1-1/4"	31.5	6"	900
1-1/2"	46.0	8"	1400

* For water with clean, perforated basket

Model 72 Simplex Basket Strainer



Technical Details

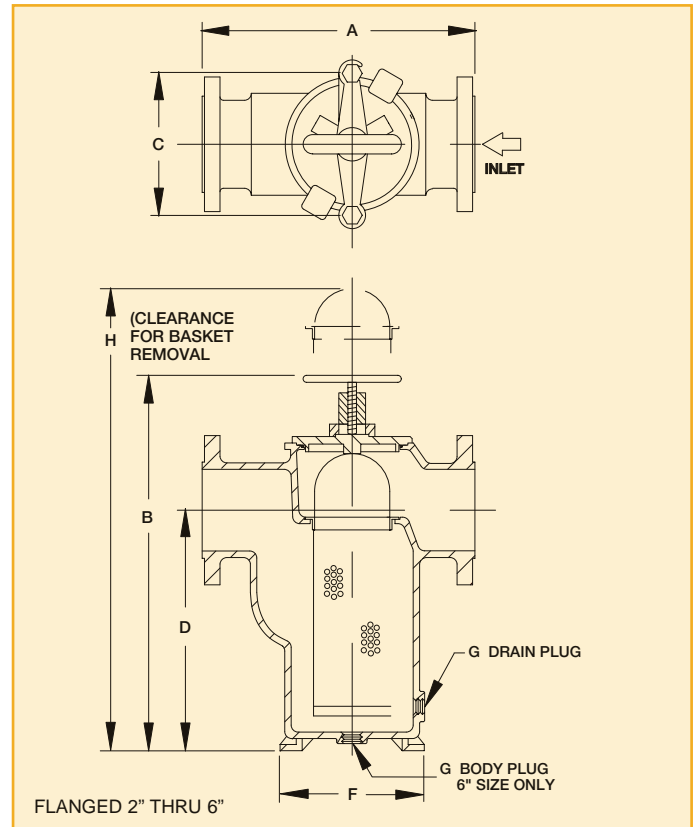
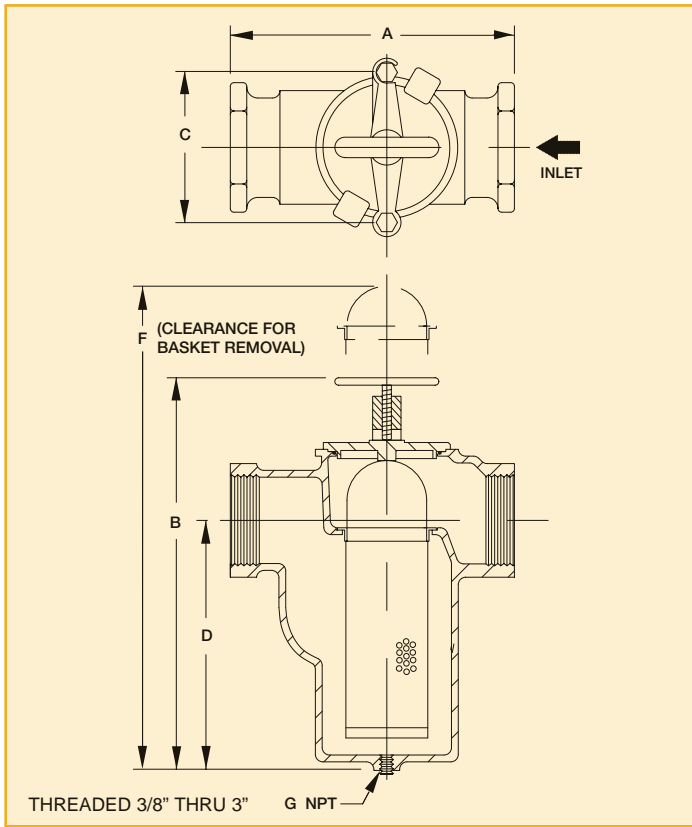

Dimensions and weights are for reference only. Contact Hayward for certified drawings.

Threaded Model 72 Dimensions (in / mm)

Pipe Size	A	B	C	D	E	F	G	H	Net Wt. - lb / kg			
									Bronze	Carbon Steel	Iron	Stainless Steel
3/8	4.00 / 102	6.63 / 168	2.88 / 73	4.00 / 102	2.38 / 60	11 / 279	3/8 / 10	-	4 / 1.8	-	4 / 1.8	-
1/2	4.00 / 102	6.63 / 168	2.88 / 73	4.00 / 102	2.38 / 60	11 / 279	3/8 / 10	-	4 / 1.8	-	4 / 1.8	-
3/4	5.38 / 137	8.38 / 213	4.00 / 102	5.00 / 127	3.06 / 78	13 / 330	1/2 / 15	-	8 / 3.6	-	7 / 3.2	-
1	5.38 / 137	8.38 / 213	4.00 / 102	5.00 / 127	3.06 / 78	13 / 330	1/2 / 15	-	8 / 3.6	7 / 3.2	7 / 3.2	7 / 3.2
1-1/4	6.75 / 172	9.88 / 251	4.88 / 124	5.88 / 149	3.88 / 99	14 / 356	1/2 / 15	-	13 / 6	-	12 / 6	-
1-1/2	7.25 / 184	11.00 / 279	4.88 / 124	7.00 / 178	4.00 / 102	16 / 406	3/4 / 20	-	16 / 7	15 / 7	15 / 7	16 / 7.3
2	8.75 / 222	13.38 / 340	6.75 / 172	7.63 / 194	5.13 / 130	21 / 533	1-1/4 / 32	-	32 / 15	36 / 16	28 / 13	31 / 14
2-1/2	10.38 / 264	14.88 / 378	8.00 / 203	8.63 / 219	6.38 / 162	26 / 660	1-1/2 / 40	-	49 / 22	52 / 24	42 / 19	51 / 23
3	11.50 / 292	17.75 / 468	8.00 / 203	11.38 / 298	6.63 / 168	28 / 711	1-1/2 / 40	-	60 / 27	60 / 27	52 / 23	60 / 27

Flanged Model 72 Dimensions (in / mm)

2	10.50 / 268	13.75 / 349	6.75 / 172	7.63 / 194	5.13 / 130	6.25 / 159	3/8 / 10	20.00 / 508	49 / 22.3	36 / 16	36.5 / 17	36 / 16
2-1/2	11.63 / 295	15.63 / 397	8.00 / 203	8.88 / 226	6.38 / 162	7.63 / 194	3/8 / 10	23.00 / 584	64 / 29.1	63 / 27	54 / 25	63 / 29
3	13.13 / 334	18.00 / 457	8.00 / 203	10.63 / 270	6.50 / 165	8.00 / 203	3/8 / 10	27.00 / 686	85 / 38.6	-	76 / 35	-
3	13.13 / 334	18.75 / 476	7.94 / 202	12.00 / 305	6.50 / 165	8.00 / 203	1/2 / 15	27.00 / 686	-	86 / 39	-	86 / 39
4	16.75 / 425	19.88 / 505	10.75 / 273	10.75 / 273	9.63 / 245	11.38 / 289	1/2 / 15	30.00 / 762	140 / 63.6	-	125 / 55	-
4	17.25 / 438	19.88 / 505	10.69 / 272	10.69 / 272	9.25 / 235	11.38 / 289	1/2 / 15	30.00 / 762	-	130 / 59	-	130 / 59
5	18.13 / 461	25.13 / 638	10.75 / 273	15.25 / 387	10.00 / 254	11.38 / 289	1/2 / 15	41.00 / 1041	182 / 82.7	-	170 / 775	-
6	19.63 / 499	28.50 / 724	10.69 / 272	18.38 / 467	10.00 / 254	11.38 / 289	1/2 / 15	46.00 / 1168	270 / 122.7	235 / 107	200 / 91	235 / 107
8	27.00 / 686	40.50 / 1029	-	27.00 / 686	13.75 / 349	17.50 / 445	1/2 / 15	60.00 / 1524	600 / 272.7	550 / 250	500 / 227	550 / 250

PROSEP FILTER SYSTEMS LTD
Unit G19
River Bank Way
Lowfields Business Park
Elland
West Yorkshire
HX5 9DN

Tel: 01422 377367

Fax: 01422 377369

Email: enquiries@prosep.co.uk

www.prosep.co.uk

Map and Directions to Prosep Filters Limited



Leave M62 at Junction 24.

At roundabout adjacent to Cedar Court Hotel take 2nd exit onto dual carriageway (A629), signposted Halifax.

Take 1st exit slip road.

At roundabout at end of sliproad, take 3rd exit off.

This is the entrance to Lowfields Business Park.

Proceed straight over 1st roundabout.

At next roundabout take 2nd exit onto River Bank Way - Prosep Filters can be found on the left after the S-bend.

[Link to Google Maps](#)