

# HIL Multi Filter Housings

Industrial Liquid



- Flow efficient range of multi element industrial liquid housings
- Designed specifically for prefiltration and clarification applications
- Available with a number of inlet/outlet port connections
- Standard and electropolished surface finishes
- Suitable for cartridge types:
  - DOE or 222 (10" to 40")
- Option for ATEX compliance directive 94/9/EC

## Specification

### STANDARD Range

#### Materials of Construction

- Housing: 316L Stainless Steel
- Seals: EPDM FDA  
Silicone FDA  
Viton® / FKM FDA
- Clamps: 304 Stainless Steel

### Two Finishes Available

- Standard Finish 'I'
  - Internal: As Welded  
Pickled and Passivated
  - External: Polished 0.8 µm Ra (32 µIn Ra)
- Electropolished Finish 'E'
  - Internal: As Welded  
Electropolished
  - External: Electropolished 0.8 µm Ra (32 µIn Ra)

### Welding

All assembly welds are full penetration.  
All welds are crevice and undercut free.  
Weld finish and detail drawings available upon request.

### Certification

Supplied as standard with vessel inspection certificate and EC Declaration of conformity.

### Material Test Certification

EN10204 3.1/2.2 supplied upon request.

### Design Code

Housings designed in accordance with the European Council Pressure Equipment Directive (PED) 97/23/EC and the UK statutory Pressure Equipment Regulations (PER) 1999 N° 2001.

### Design Basis

ASME VIII Division 1.

CE Working Condition PED 97/23/EC			Maximum Pressure +FV		
Fluid Group	State	Temperature	3 Round	5/7 Round	8/10 Round
Non Dangerous	Liquid	-10 °C (14 °F) to 150 °C (302 °F)	10 barg (145 psig)	10 barg (145 psig)	10 barg (145 psig)
Non Dangerous	Gas		8 barg (116 psig)	4 barg (58 psig)	3 barg (44 psig)
PED Conformity Assessment Category			CAT I	CAT I	CAT I

ATEX Working Condition PED 97/23/EC			Maximum Pressure +FV		
Fluid Group	State	Temperature	3 Round	5/7 Round	8/10 Round
Non Dangerous	Liquid	-10 °C (14 °F) to 135 °C (275 °F)	10 barg (145 psig)	10 barg (145 psig)	10 barg (145 psig)
Non Dangerous	Gas		8 barg (116 psig)	4 barg (58 psig)	3 barg (44 psig)
PED Conformity Assessment Category			CAT I	CAT I	CAT I

Note: All housings are full vacuum rated.

# HIL Multi Filter Housings Industrial Liquid

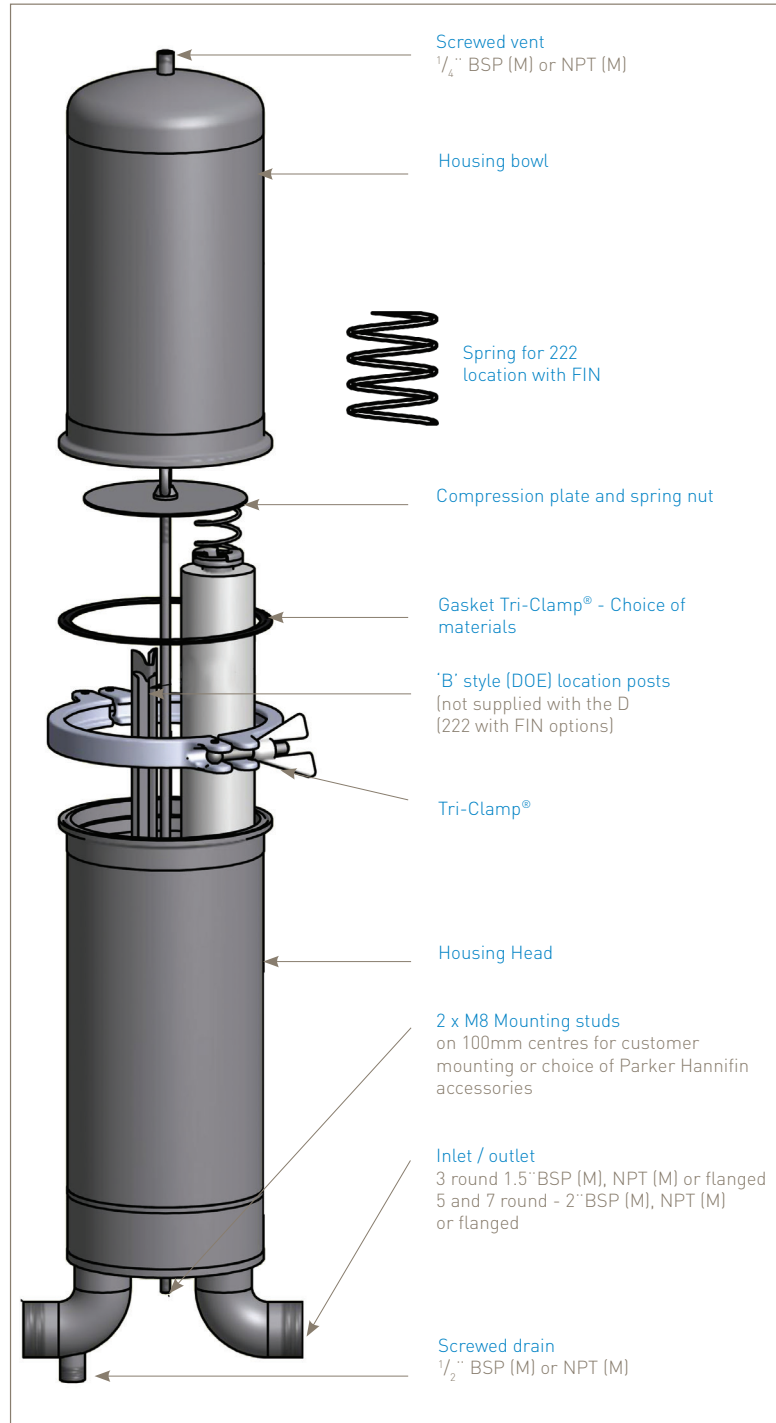
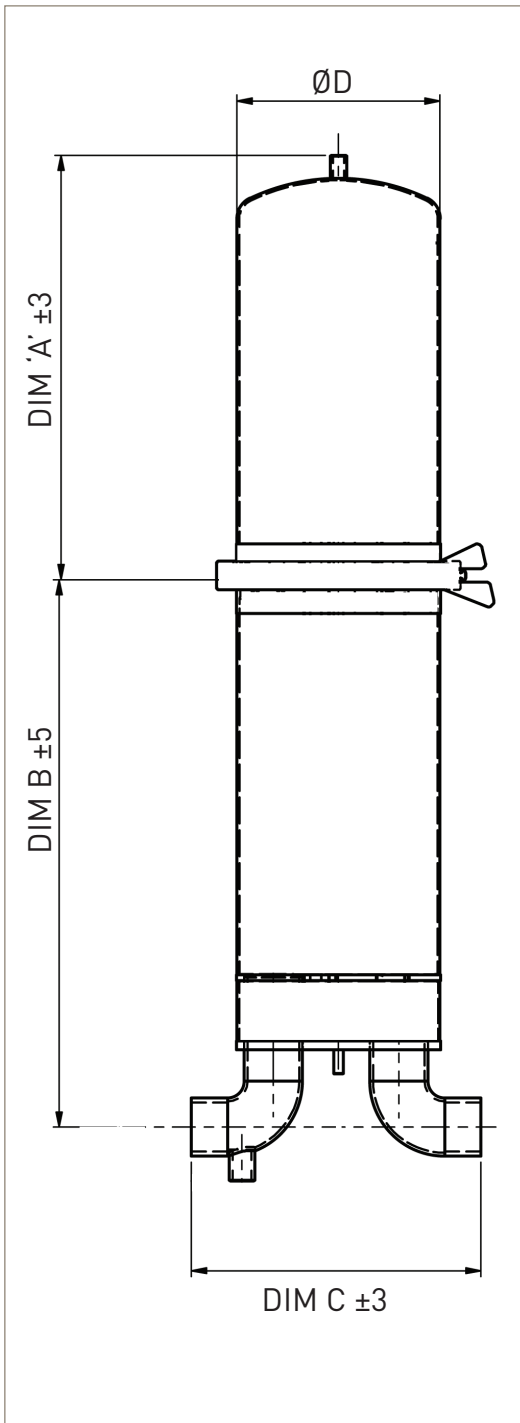

	Dimensions							Approximate weight and volume		
	A'	B'	C'			'D'	BOWL	TOTAL (Threaded version only)	VOLUME	
			BSP (M)	NPT (M)	FLANGED					
3 ROUND	10"	101 mm (4.0 in)					2.0 kg (4.4 lbs)	8.9 kg (21.0 lbs)	10.4 L (2.75 USg)	
	20"	348 mm (13.7 in)	455 mm (17.9 in)	230 mm (9 in)	230 mm (9 in)	294 mm (11.6 in)	168 mm (6.6 in)	4.0 kg (8.8 lbs)	11.0 kg (24.0 lbs)	15.7 L (4.15 USg)
	30"	598 mm (23.5 in)						6.0 kg (13.2 lbs)	13.1 kg (29.9 lbs)	21.0 L (5.5 USg)
	40"	848 mm (33.4 in)						8.0 kg (17.6 lbs)	15.2 kg (33.5 lbs)	26.3 L (6.8 USg)
5 & 7 ROUND	10"	109 mm (4.3 in)						1.6 kg (3.5 lbs)	12.9 kg (28.0 lbs)	18.0 L (4.6 USg)
	20"	360 mm (14.2 in)	468 mm (17.7 in)	296 mm (11.7 in)	296 mm (11.7 in)	347 mm (13.7 in)	219 mm (8.6 in)	4.4 kg (9.7 lbs)	15.7 kg (35.0 lbs)	27.0 L (7.0 USg)
	30"	610 mm (24.0 in)						7.1 kg (15.6 lbs)	18.4 kg (41.0 lbs)	36.0 L (9.3 USg)
	40"	860 mm (33.9 in)						9.8 kg (21.6 lbs)	21.1 kg (46.5 lbs)	45.0 L (11.7 USg)

Refer to coding structure for configuration options.

# HIL Multi Filter Housings

Industrial Liquid

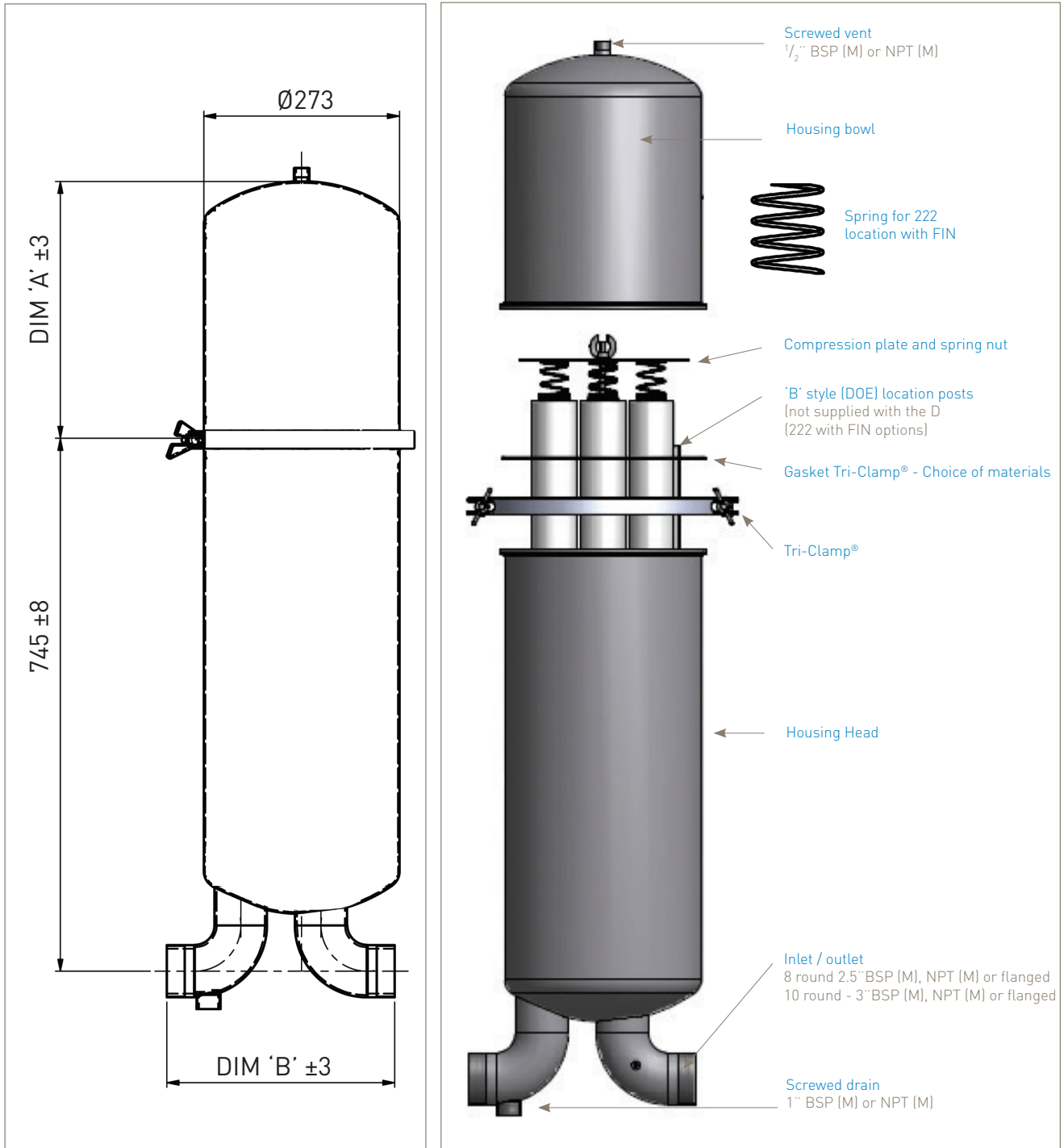

		Dimensions				Approximate weight and volume		
		A'	B'			BOWL	TOTAL (Threaded version only)	VOLUME
		BSP (M)	NPT (M)	FLANGED				
8 ROUND	20"	107 mm (4.2 in)				2.2 kg (5.0 lbs)	20.0 kg (44.0 lbs)	42.0 L (11.1 USg)
	30"	357 mm (14 in)	316 mm (12.4 in)	332 mm (13.1 in)	356 mm (14 in)	5.7 kg (12.5 lbs)	23.5 kg (52.0 lbs)	56.0 L (14.8 USg)
	40"	607 mm (24 in)				9.0 kg (20 lbs)	27.0 kg (60.0 lbs)	69.0 L (18.2 USg)
10 ROUND	20"	107 mm (4.2 in)				2.2 kg (5.0 lbs)	22.2 kg (49.0 lbs)	45.0 L (11.9 USg)
	30"	357 mm (14 in)	410 mm (16.1 in)	410 mm (16.1 in)	382 mm (15 in)	5.6 kg (12.3 lbs)	25.6 kg (56.4 lbs)	59.3 L (15.7 USg)
	40"	607 mm (24.0 in)				9.0 kg (20 lbs)	29.0 kg (63.9 lbs)	73.5 L (19.4 USg)

Refer to coding structure for configuration options.

# HIL Multi Filter Housings Industrial Liquid

## Product coding

	Connection	Code	Max Flow	
HIL **03	1.5" Connections	Y	175 L/min	45 USg/min
HIL **05 /07	2" Connections	C	280 L/min	72 USg/min
HIL **08	2.5" Connections	X	420 L/min	109 USg/min
HIL **10	3" Connections	D	650 L/min	168 USg/min

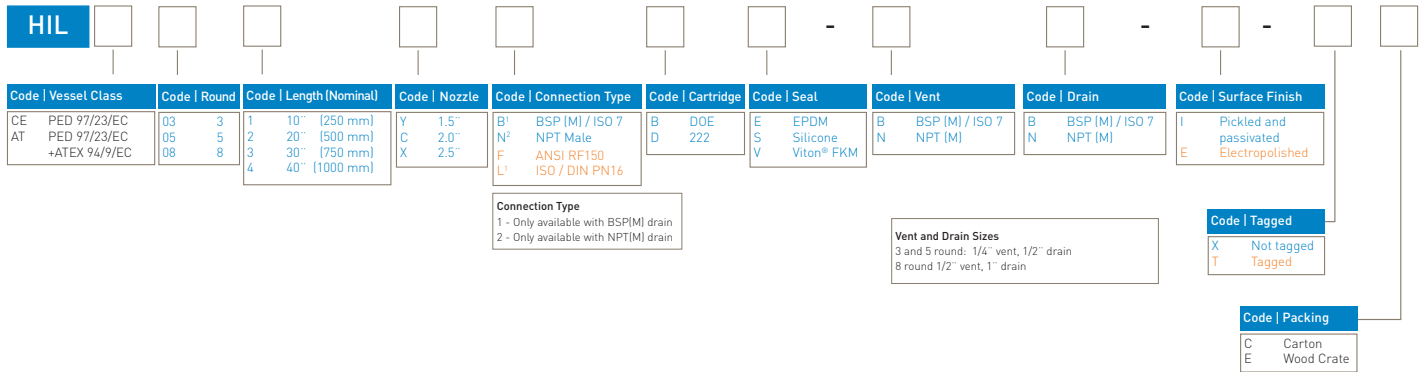

Only 62 and 64 mm diameter cartridges can be used in the 7 and 10 round housings.

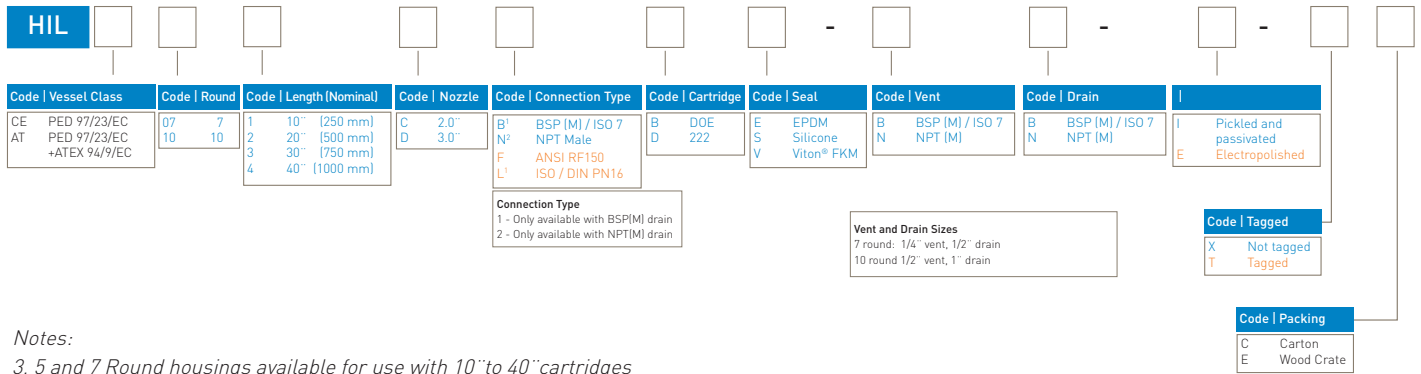

### Notes:

3, 5 and 7 Round housings available for use with 10" to 40" cartridges  
8 and 10 Round housings available for use with 20" to 40" cartridges

Delivery schedules (excluding shipping)

Blue Options - 2-3 working weeks

Orange Options - 4-5 working weeks

Tri-Clamp<sup>®</sup> is a trademark of Alfa-Laval, Inc.

Viton<sup>®</sup> is a registered trademark of DuPont Performance Elastomers L.L.C..

# HIL Multi Filter Housings

Industrial Liquid



## Accessories

### Adjustable legs.

Accessory Kit

3 round  
639504203 (XLGSS12IL1)

5 and 7 round  
639504204 (XLGSS12IL2)

8 and 10 round  
639504205 (XLGSS13IL1)

Adjustable legs giving centre to floor height adjustment between 50 and 375 mm for 3,5 and 7 round and 50-300 mm for 8 and 10 round. (clearance required for drain)

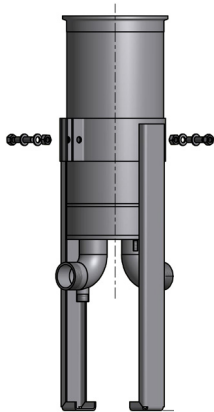

### Fixed legs.

Accessory Kit

3, 5 and 7 round only  
639504206 (XLGSS12IL3)

Fixed base support for M8 mounting studs giving centre to floor height of 230 mm. Vessel to be properly supported on the pipework as close as possible to the inlet/outlet.

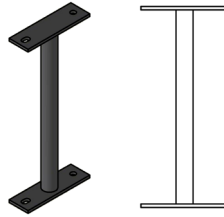

### Customer mounting, 3, 5 & 7 round only.

Two M8 mounting studs are provided as shown to allow the customer to custom mount the housing as they require, alternatively we provide accessories shown.

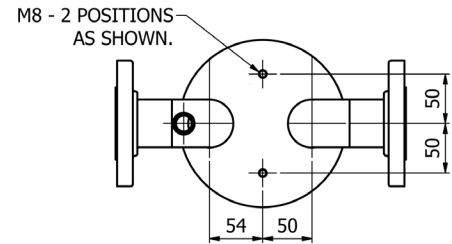

Note A  
Gap available for 50 mm (2 in) wide support.

### Wall mounting, 3, 5 & 7 round only.

Accessory Kit - 639504207 (XMBSS12IL1)

Wall mounting bracket. Customer to ensure wall strength and if necessary provide a backing plate.

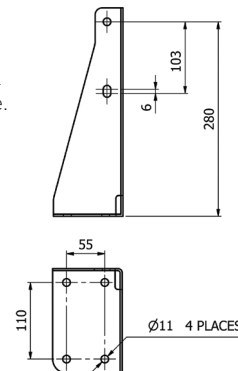
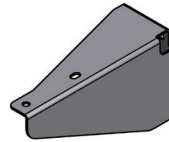

HIL Pressure Gauge			
Type	Connection	Pressure	Ordering Code
All stainless steel wetted parts with glycerine fill fluid (includes adaptor for assembly to housing. Also includes adaptor for connecting vent valve [1/4" BSP(F)/1/4" NPT (F)])	1/4" / 1/2" BSP	0 - 10 barg	639504201 (XPGSS03BS01)
	1/4" / 1/2" NPT	0 - 10 barg	639504202 (XPGSS03NP01)

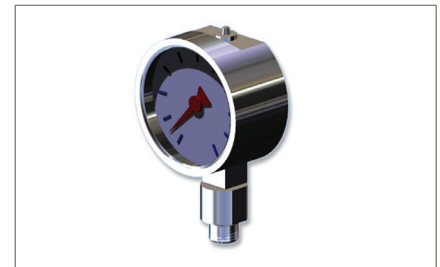

Industrial 1 Piece Ball Valve		
Type	Connection	Ordering Code
316 stainless steel 1 piece ball valve with PTFE ball. Male / female.	1/4" BSP	639502594 (XVASS03BS6)
	1/4" NPT	639502595 (XVASS04BS1)
	1/2" BSP	639504218 (XVASS05BS3)
	1/2" NPT	639504220 (XVASS03NP1)
	1" BSP	639504221 (XVASS04NP2)
	1" NPT	639504219 (XVASS05NP1)

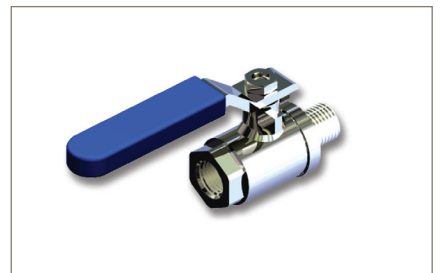

PROSEP FILTER SYSTEMS LTD  
Unit G19  
River Bank Way  
Lowfields Business Park  
Elland  
West Yorkshire  
HX5 9DN

**Tel: 01422 377367**

**Fax: 01422 377369**

Email: [enquiries@prosep.co.uk](mailto:enquiries@prosep.co.uk)

[www.prosep.co.uk](http://www.prosep.co.uk)

**Map and Directions to Prosep Filters Limited**

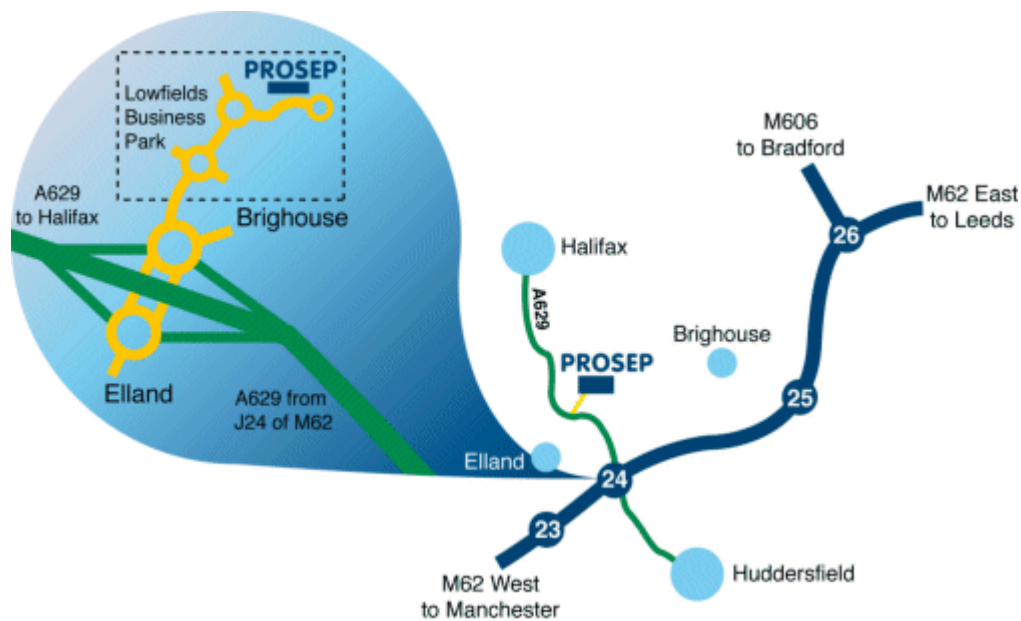

Leave M62 at Junction 24.

At roundabout adjacent to Cedar Court Hotel take 2nd exit onto dual carriageway (A629), signposted Halifax.

Take 1st exit slip road.

At roundabout at end of sliproad, take 3rd exit off.

This is the entrance to Lowfields Business Park.

Proceed straight over 1st roundabout.

At next roundabout take 2nd exit onto River Bank Way - Prosep Filters can be found on the left after the S-bend.

[Link to Google Maps](#)